

Terminals : male FASTON (.250 series / 6,3x0,8 mm)

PFG05C

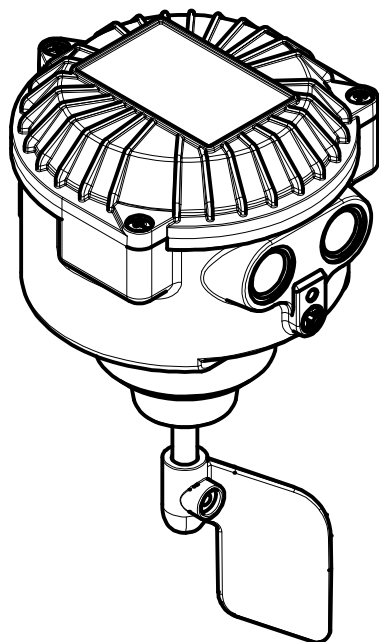

Model	PFG05C
Weight	1,6 [kg]
Power supply	- Bivoltage 115/230[V] (50...60Hz) - 4[W] - Bivoltage 24/48[V] (50...60Hz) - 4[W] - DC 24[V] ±15% - 4[W]
Signal	SPDT / max. 10[A]-250VAC
IP grade	IP65
Housing	Aluminium (powder coated)
Connection	G2" 1/2 - Aluminium
Ambient temperature	-20 < Ta < +70 [°C] -40 < Ta < +70 [°C] <i>LOW TEMPERATURE versions only (PFG.../B)</i>
Process temperature	-20 < Tp < +70 [°C] -40 < Tp < +70 [°C] <i>LOW TEMPERATURE versions only (PFG.../B)</i>
Pressure range	+0,8 ... +1,1 bar [abs] +0,8 ... +5 bar [abs] <i>(non ATEX versions)</i>
Directives	2011/65/EU (RoHS) 2014/30/EU (EMC) 2014/34/EU (ATEX) 2014/35/EU (LVD)
ATEX Marking	Ex II 1/2 D Ex ta/tb IIIC T85°C IP65 Da/Db Ex II 3 D Ex tc IIIB T85°C Dc (Lamp version)
IECEX Marking	Ex ta/tb IIIC T85°C Da/Db

® CAMLogic Via dell'Industria 12 42025 Cavriago (RE) - ITALY www.camlogic.it		DRAWING N.	SHEET:
		0602_0002_00	1 OF 4
GENERAL TOL.: ISO 2768-mH	UNLESS OTHERWISE SPECIFIED DIMENSION ARE IN [mm]	DRAWING FROM CAD SYSTEM - REFER TO 3D MODEL FOR MISSING DIMENSION - NO MANUAL MODIFICATION ALLOWED	SCALE: 1:3
			REV: 1 DATE 21.09.2021

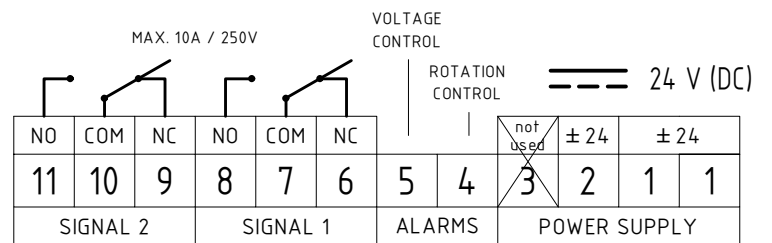
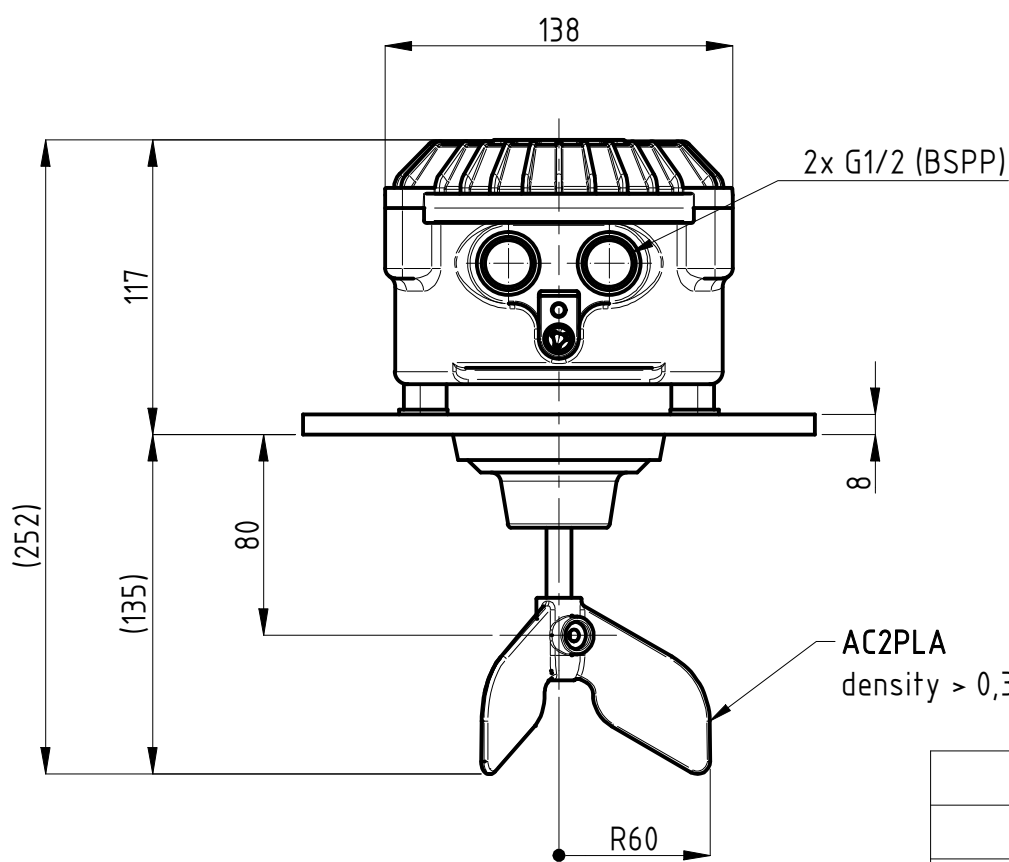
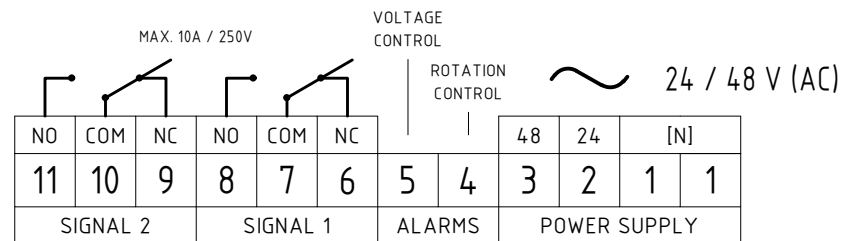
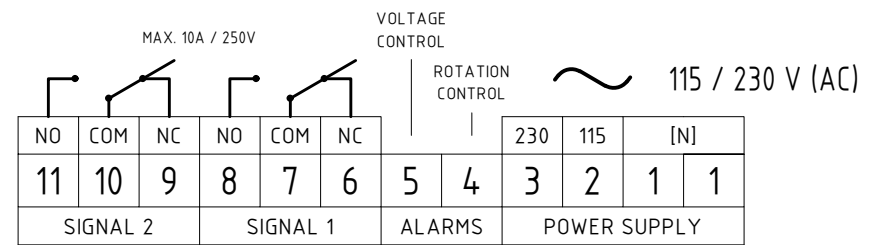
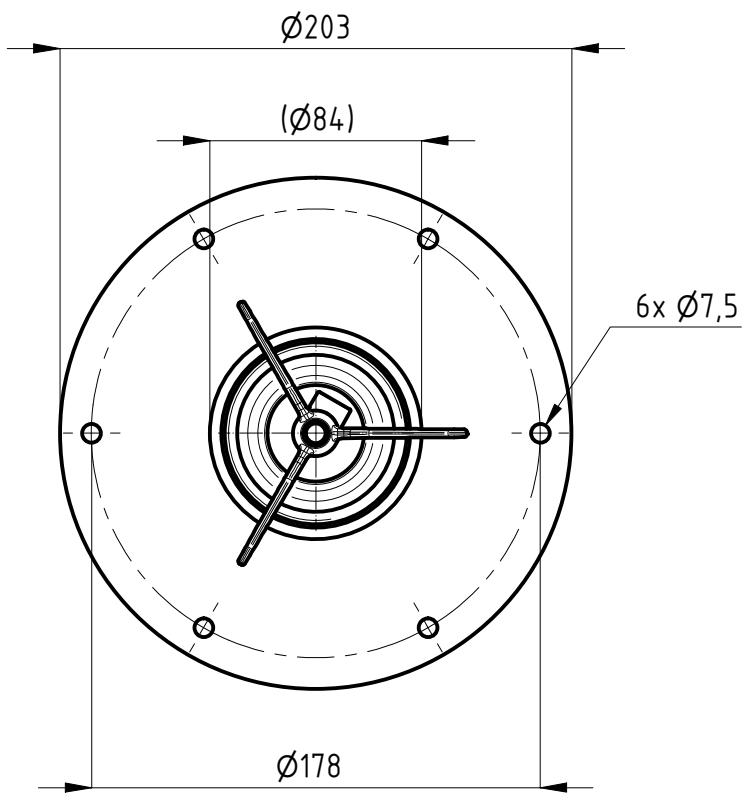

Terminals : male FASTON (.250 series / 6,3x0,8 mm)

AC2PLA
density > 0,3 kg/dm³

PFG05C/F

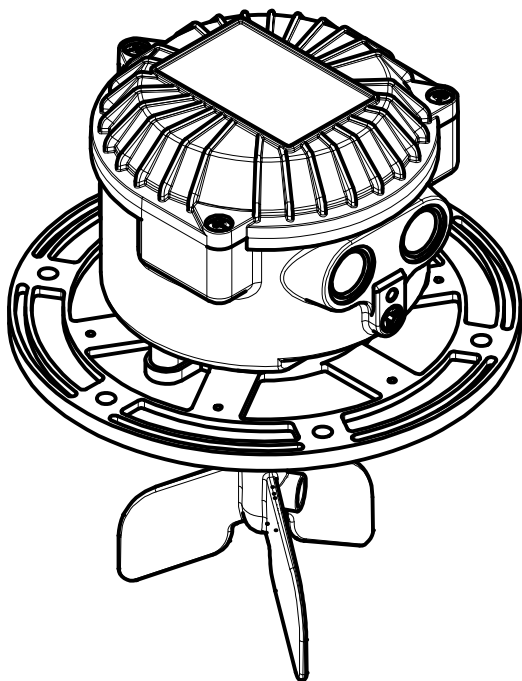

Model	PFG05C/F
Weight	2,1 [kg]
Power supply	-Bivoltage 115/230[V] (50...60Hz) - 4[W] -Bivoltage 24/48[V] (50...60Hz) - 4[W] -DC 24[V] ±15% - 4[W]
Signal	SPDT / max. 10[A]-250VAC
IP grade	IP65
Housing	Aluminium (powder coated)
Connection	Flange - Aluminium
Ambient temperature	-20 < Ta < +70 [°C] -40 < Ta < +70 [°C] <i>LOW TEMPERATURE versions only (PFG.../B)</i>
Process temperature	-20 < Tp < +70 [°C] -40 < Tp < +70 [°C] <i>LOW TEMPERATURE versions only (PFG.../B)</i>
Pressure range	+0,8 ... +1,1 bar [abs] +0,8 ... +5 bar [abs] <i>(non ATEX versions)</i>
Directives	2011/65/EU (RoHS) 2014/30/EU (EMC) 2014/34/EU (ATEX) 2014/35/EU (LVD)
ATEX Marking	Ex II 1/2 D Ex ta/tb IIIC T85°C IP65 Da/Db Ex II 3 D Ex tc IIIB T85°C Dc (Lamp version)
IECEX Marking	Ex ta/tb IIIC T85°C Da/Db

® CAMLogic Via dell'Industria 12 42025 Cavriago (RE) - ITALY www.camlogic.it		DRAWING N.	SHEET:
		0602_0002_00	2 OF 4
GENERAL TOL.: ISO 2768-mH	UNLESS OTHERWISE SPECIFIED DIMENSION ARE IN [mm]	DRAWING FROM CAD SYSTEM - REFER TO 3D MODEL FOR MISSING DIMENSION - NO MANUAL MODIFICATION ALLOWED	SCALE: 1:3
			REV: 1 DATE 21.09.2021

PADDLES

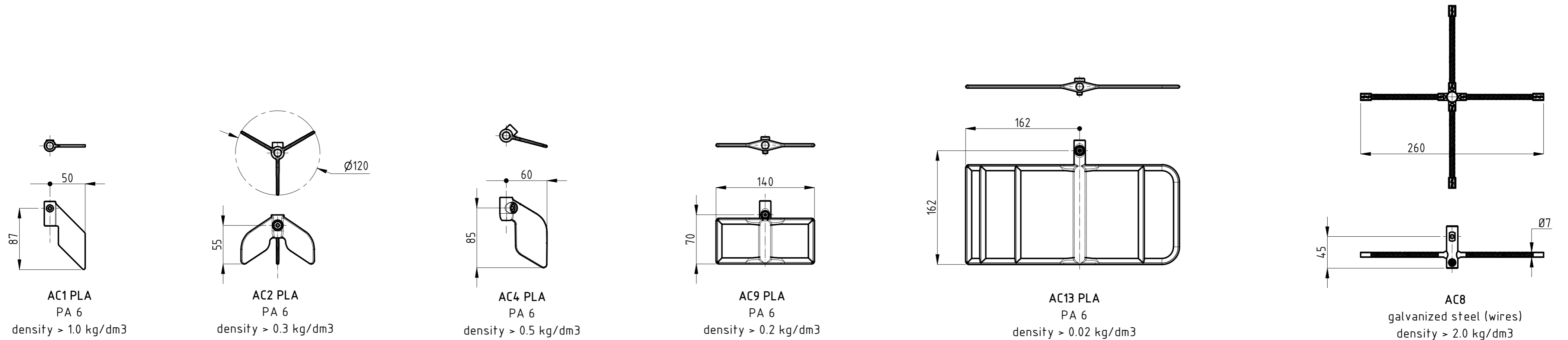
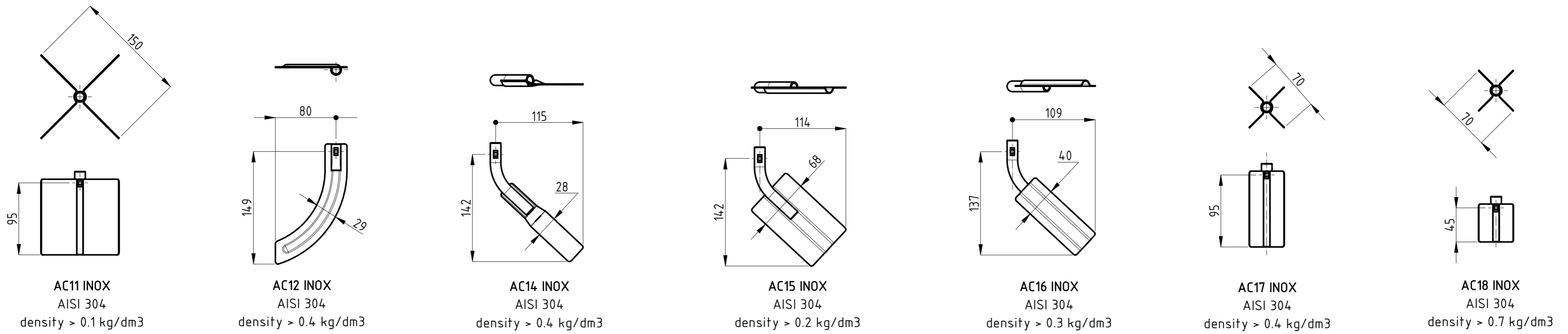
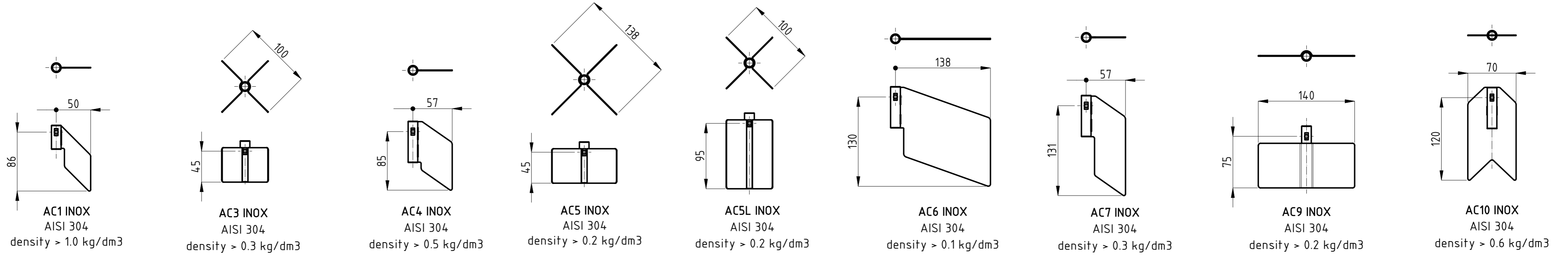

OPTIONS

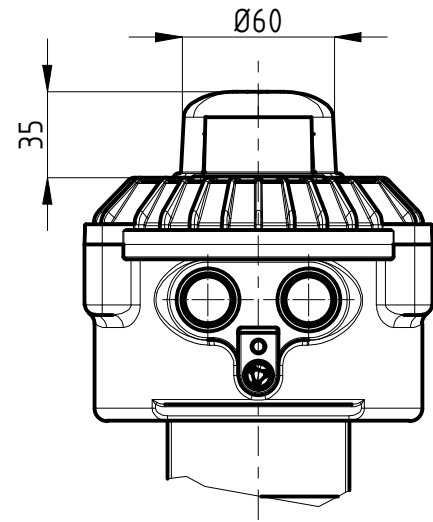

SIGNAL LAMP (PFG05.../L)

Adds a LED lamp on top. The lamp could be connected to NC contact (MIN level - empty), or NO contact (MAX level - full).

Must define a single power supply voltage: 24[V]
48[V]
115[V]
230[V]

NOTE

Model with lamp can be installed only in Atex zone 22
Marking: Ex II 3 D Ex tc IIIB T85°C Dc

LOW TEMPERATURE (PFG05.../B)

Extends the range of use of the indicator down to a minimum temperature of -40 °C
Intelligent automatic operation: when the temperature exceeds + 20 °C it stops heating (heating OFF), it is reactivated when the temperature falls again below + 20 °C (heating ON)

Must define a single power supply voltage: 24[V]
48[V]
115[V]
230[V]

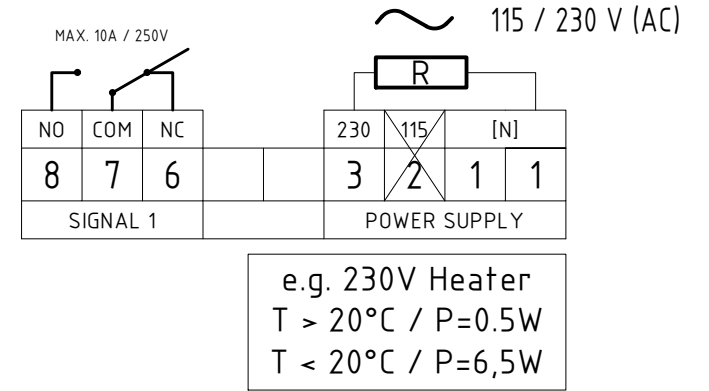

DOUBLE DRY CONTACT

Adds a second signal contact SPDT (terminals 9 - 10 - 11)

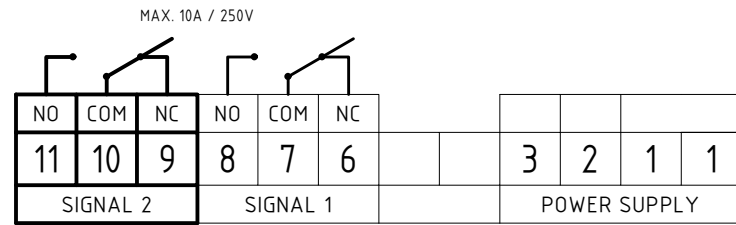

VOLTAGE CONTROL

Adds an alarm in case of power supply failure. When power supply is OFF, a relay closes terminals 5 and 7

Must define a single power supply voltage: 24[V]
48[V]
115[V]
230[V]

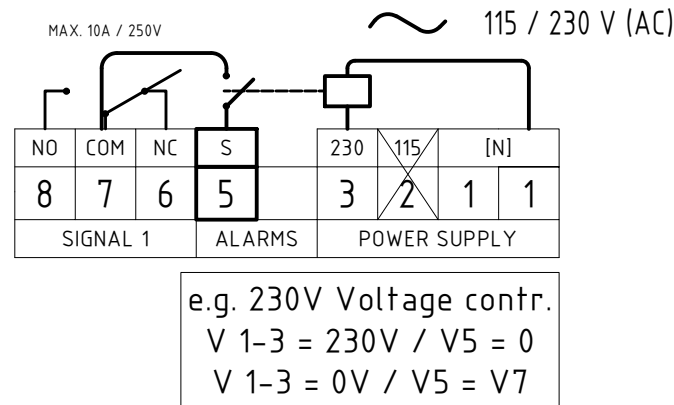

ROTATION CONTROL

Adds a signal to indicate shaft rotation. When the shaft rotates, a microswitch generates a pulse signal (8 pulse / rotation) between terminals 1 and 4. On request, it is possible to have the pulsed signal between terminals 4 and 7.

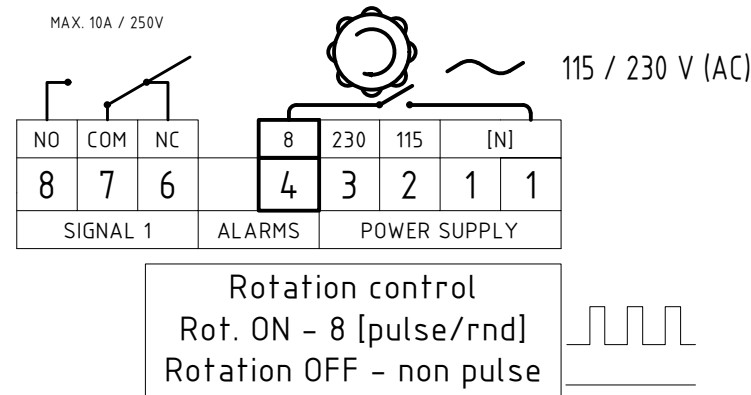

SPRING TERMINAL BLOCK

Terminals with spring terminal design. No tool needed for wires connection. 0,13 - 2,5mm² (AWG26 - AWG14)

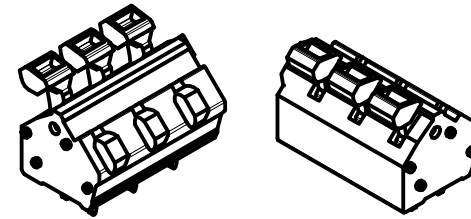

SCREW TERMINAL BLOCK

Terminals with screw terminal design (flat head) 0,05 - 2,5mm² (AWG30 - AWG12)

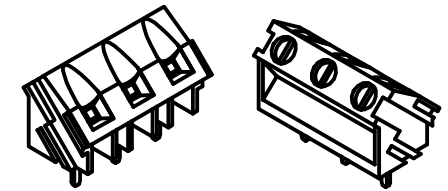

4rpm GEARMOTOR

Increase paddle speed (4 rpm) to reduce product detection delay time (response time ~ 1,5s)

CONDENSATION FILTER

It allows the exchange of air temperature and pressure with the ambient, preventing the formation of condensation. The option does not alter the IP grade and the Ex marking of the device.